 **BLOCKS**TM
LEARN • DESIGN • BUILD

E-blocksTM user guide

matrixmultimedia

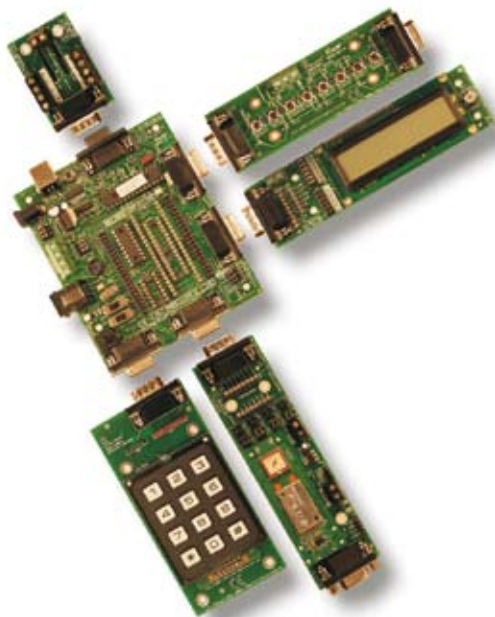

Fig 1 - An E-blocks system

Contents:

- 1 Introduction to E-blocks**
- 2 Examples of E-blocks systems**
- 3 Electrical considerations**
- 4 Physical properties**
- 5 Available E-blocks and accessories**
- 6 Warranty statement**

Copyright 2007 Matrix Multimedia Limited
PIC and PICmicro are trademarks of Arizona Microchip inc.
AVR is a trademark of the Atmel Corporation
E-blocks is a trademark of Matrix Multimedia Limited.

I Introduction to E-blocks

Congratulations. You have just bought into the world's most flexible range of electronics system development kits. The E-blocks range is made up of more than 150 individual products that allows you to both learn how electronic systems work, and to rapidly develop electronic systems of your own. The range is split into several parts:

Hardware

There are two kinds of hardware E-blocks:

Upstream boards

'Upstream' is a computing term which indicates that this is the board that controls the flow of information in a system. Upstream boards are usually device programmers of some kind. Any device which contains 'intelligence' and can dictate the direction of flow of information on the bus can be thought of as an 'upstream' device. Examples include microcontroller boards and Programmable Logic Device boards. You can see a full list of boards at www.matrixmultimedia.com.

Downstream boards

Any device which responds to these changes and whose behaviour is determined by another device can be thought of as a 'downstream' device. Examples include LED boards, RS232 boards, internet boards etc.

Downstream boards are controlled by the upstream board - but information can flow into them and from them.

Upstream and downstream boards can be snapped together to form a complete electronic systems for learning and development.

Accessories

In addition to the circuit boards themselves you will find that there are more than 60 sensors and accessories - including the Accelerometer sensor shown in Figure 2.



Fig 2 - Accelerometer

Software

The software you use will depend on your choice of upstream board(s). In the E-blocks range you will find C compilers, assemblers and Flowcode - a unique graphical programming tool based on flow charts which allows those with little experience to develop complex electronic systems.



Fig 3 - Flowcode 3

Curriculum and applications

If you are just starting to learn electronics, or if you are an experienced engineer learning VHDL, you will find that the E-blocks range is supported by a fantastic amount of curriculum materials, datasheets, and project articles.

Much of this is available on CD ROM, but you will also find our web site a great source of information.

User guide

This short guide will introduce you to the E-blocks system and explain how it works from electrical and mechanical points of view. It will also give you some hints and tips on how to use E-blocks so that you can get the best from your equipment.

2 Examples of E-blocks systems

You can construct a wide variety of projects with E-blocks. On this page you can see a few examples:

Figure 4 shows a simple internet based temperature logger. The PICmicro microcontroller gathers data from a temperature probe via the sensor interface and then publishes a simple web page with a 10 bit temperature

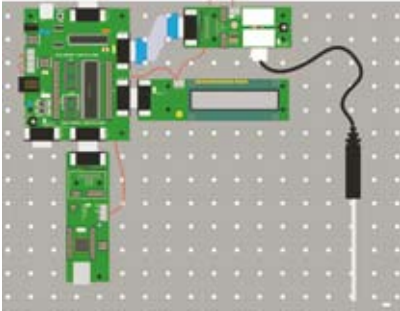

Fig 4 - Internet based temperature logger

reading. A further program - written in Java - gathers temperature data from the web page and produces a graph of temperature against time.

Figure 5 shows an electronic bug using mobile phone technology. A small patch board contains a microphone and amplifier that feeds into a Sony GSM module with SIM card. An AVR microcontroller is used to detect an incoming call and then channel local sound to the incoming caller who can hear what is going on in the room. A keypad and LCD allow

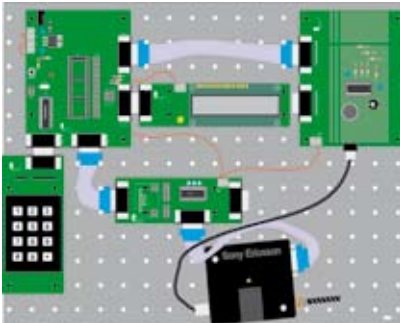

Fig 5 - Mobile technology snooper

various set ups with dial out at pre-determined times.

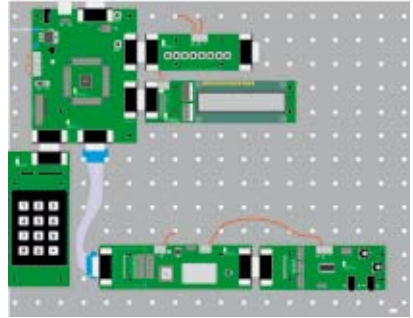

Fig 6 - ARM based Bluetooth system

Figure 6 shows a project which uses an ARM microcontroller to communicate to a mobile phone using Bluetooth. The Bluetooth board interfaces to the ARM serial port to allow users to set up the communication system and transfer data between Bluetooth hosts. The Bluetooth audio CODEC board allows two way transfer of audio between Bluetooth systems.

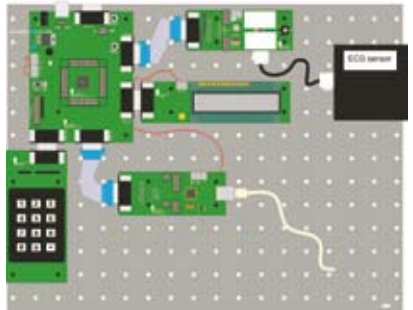

Fig 7 - ECG system

In figure 7 you can see an Electro CardioGram (ECG) data logging system. ECG data is gathered using a sensors board and an ARM microcontroller board which connects to a PC using a USB interface board. PC software, written in Visual Basic, uses the virtual COM port driver provided to interface with the system and gather ECG data. A Keypad and LCD display provide control of the system.

3 Electrical considerations

E-blocks are built on a bus-based concept based on D-type connectors. D-types are used because they are rugged and because their physical properties allow you to snap E-blocks together to form a system which mounts onto a backplane.

Each E-block D-type connector consists of 8 bits and ground - 9 connections in total. Upstream boards connect using 9 way D-type sockets (female). Downstream devices connect to E-blocks using 9 way D-type plugs (male). This combination works remarkably well as most system topologies require upstream devices to connect directly to downstream ones. On each D-type connector bit 0 is on pin 1, bit 1 is on pin 2, etc. Pin 9 is designated 0V.

Where two upstream devices need to be connected together a gender changer or In-



Fig 8 - D-type connectors

sulation Displacement Connector (IDC) cable with two IDC sockets on can be used.

Adding power

Power is routed separately between E-blocks using simple screw terminals and stripped wires. This facilitates the interoperation of E-blocks with different voltage levels (notably 3.3V and 5V). Most downstream E-blocks are compatible with 3.3V. All upstream E-blocks have power outputs on screw terminal connectors. Upstream E-blocks are powered by applying a higher voltage via a power jack connector and use a regulator to generate power for other E-blocks in the system. As 0V is connected to all blocks through the 9 way D-type connectors, it is only necessary to connect +V to all E-blocks - ground connects via the D-type. To neaten up more permanent systems power wires can be looped under

E-blocks and under the backplanes.

On the photograph in Figure 9 you can clearly see the red power wires linking the E-blocks together. This design also routes 14V from the Multiprogrammer to the Proto board.

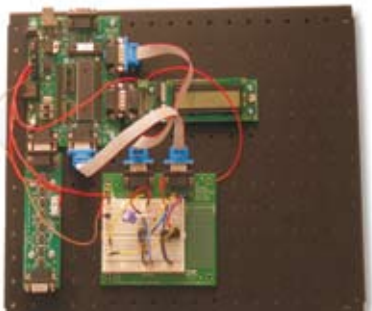

Fig 9 - Example E-blocks system

Using ZIF sockets

It is possible to use Zero Insertion Force (ZIF) sockets with those upstream boards with DIL sockets. ZIF sockets are useful where the chips will be removed from the programmer many times. Some E-blocks boards may have other components close to the DIL socket in question. If this is the case then you can simply insert additional DIL sockets to gain enough height so that the ZIF socket can be satisfactorily inserted.



Fig 10

Circuit diagrams

Each E-blocks board has an accompanying technical datasheet. In the datasheet you will find a complete description of the hardware, test instructions, and a full circuit diagram with a description. For many boards you will also find sample code, coding instructions, and application notes. Datasheets are available on our web site: www.matrixmultimedia.com.

Understanding the patch system

Most 'downstream' E-blocks include a patch system that gives you flexibility in the connections that are made between the upstream and downstream E-blocks. The patch system has two parts: link blocks that dictate whether the default connections are used or whether the patch system is used, and the patch connectors themselves.

Looking at the graphic of the sensors board in Figure 11:

For this board when the link blocks are in the default (top) position then the default wiring is chosen. Default wiring is optimized for ease of connection between upstream and downstream boards for the PICmicro range of processors. For example the Tx and Rx lines of the PICmicro are usually on bits 6 and 7 respectively, so you will find that the default connections on downstream boards communications boards (e.g. RS232 board) are for bits 6 and 7.

For the Sensor board shown above the default connections are as follows:

- Bit 0 LDR (Light Dependant Resistor)
- Bit 1 RV1 (Resistor-Variable 1)
- Bit 2 Digital sensors out
- Bit 3 Analogue sensor
- Bit 4 Digital sensor in

The bits 0 to 4 have been chosen because on many devices in the PICmicro range the A/D inputs are on bits 0 to 4 of the port.

If you wanted to use another processor that needed the LDR input on bit 3 then you would change the link from the 'default' position to the 'patch' position (bottom) and use a small jumper wire to make the connection between the LDR output and bit 3 of the D-type as shown in Figure 13 below. You can see the new block diagram equivalent in figure 14.

Get the circuit you want

This technique allows you to get the exact circuit you want. If you need to copy another circuit using E-blocks hardware you should find that the patch system allows you to de-

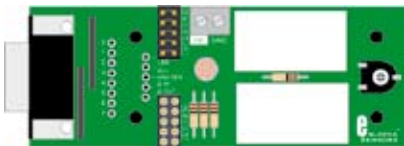

Fig 11 - A sensor board

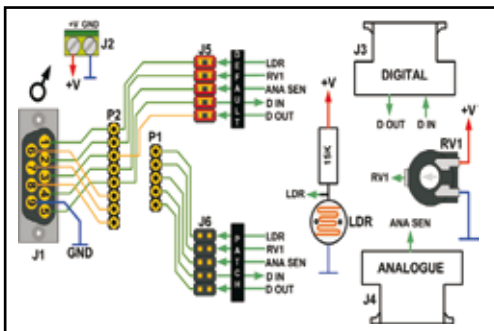

Fig 12 - Sensor board block diagram

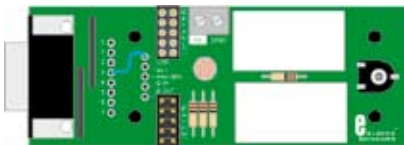

Fig 13 - A sensor board in patch mode

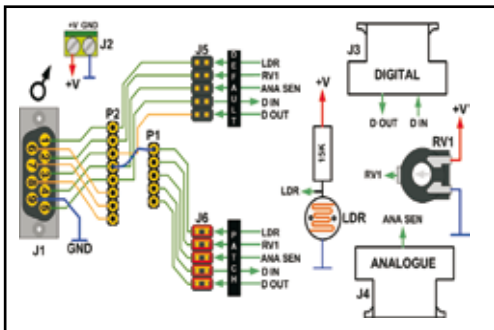

Fig 14 - Patched sensor board diagram

velop it. Note that the turned pin connectors on the patch system are design are compatible with special prototyping leads: these are a little more expensive than single strand wire - but they will last longer and will not break off in your prototype board or patch connectors.

Sharing a port

There are times when you need to split a port into several sections, or where signals on a port need to be shared between two or more downstream E-blocks boards. In this case you need to use a splitter cable. As an example of this: supposing that you wanted to develop a system that used two external analogue sensors. The Sensor board only has the capability for one external analogue sensor, so you need to use a splitter cable and the patch system to make the appropriate connections. The resulting system would look something

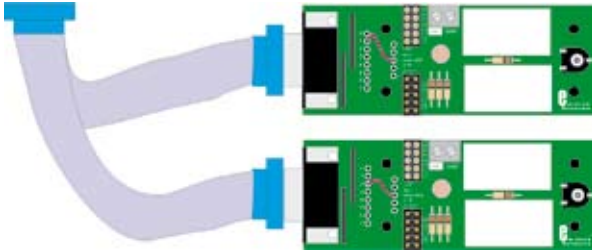

Fig 15 - Two sensor boards and a splitter cable

like the one shown in Figure 15. The splitter cable allows you to connect one upstream port to two downstream ports using IDC (Insulation Displacement Connector) connectors and ribbon cable. Here the link blocks on both boards are in the 'patch' position. On the top board the Analogue sensor is routed to bit 1, and on the bottom board the Analogue sensor is routed to bit 2. This technique allows you share ports between several devices - this is particularly convenient for communications systems where a device's serial port has to be shared.

Protecting E-blocks circuitry

Where possible leaded components have been used for all devices on E-blocks boards that can be subjected to electrical damage. This means that in the case where devices on the E-blocks boards do become damaged, the task of replacing them is very simple. Some upstream boards (ARM processor boards and FPGA board) make use of surface mounted technology components which can not be socketed and which are not easy to

solder. In these cases we have used smaller daughter board so that if the key device is broken then you can simply order a new daughter board.

To protect upstream components, all downstream E-blocks have been developed with protective resistors so that it is not possible to damage an upstream E-block by improperly declaring an input as an output, and having two output pins with different output levels clash.

However there are circumstances where it will still be possible to electrically damage

your E-blocks:

- When using screw terminal connectors turn power off when routing power wires.
- When connecting two upstream boards together with a gender changer or IDC cable then you are connecting one output to another. It is strongly recommended that you use protective resistors for the lines you need to connect to prevent chip damage.
- Although modern chips are less prone to static damage these days, you are advised to make sure you are earthed before handling E-blocks circuit boards. If you have not got access to an antistatic wristband then quickly touching a radiator or other earthed device will minimise the likelihood of static damage.
- When using a patch or prototype board you have the opportunity to connect external components directly to the pin of the microcontroller or CPLD device. This also means that you have the opportunity to short circuit the device to 0V or +V.

4 Physical properties

E-blocks can be mounted onto a metal backplane to form a completely rugged system. To facilitate this each E-block is fitted with 4

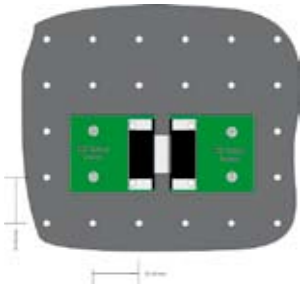

Fig 16 - Physical relationship of backplane to E-blocks
off 3 mm holes spaced at multiples of 20mm. M3 bolts can be used to mount the E-blocks onto a backplane which has 4mm holes on a regular 20mm grid.

The spatial relationship between the mounting holes on the backplane, the holes on the E-blocks and the spacing of each D-type plug and socket on the E-blocks are such that each E-block will fit into another, and yet still be mountable on the backplane.

Mounting options for backplanes

There are several options for mounting E-blocks on a backplane depending on your circumstances:

Temporary mounting with pillars

Custom moulded circuit board pillars are available which allow you to loosely mount boards to the backplane. This is ideal if you are working through a course and frequently reconfiguring the E-blocks system to give yourself experience of different systems. Note that these pillars are very tight initially but soon loosen up. This is shown in profile in Fig 17.

If you are reconfiguring your E-blocks system

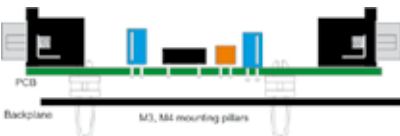

Fig 17 - Board with mounting pillars

less frequently then we suggest that you use M3 bolts on all your E-blocks and that you use a metal backplane to mount them on. The E-blocks can be mounted on the backplane with M3 self locking nuts - these will keep the bolts secured onto the circuit board and will act as spacers to keep the board clear of the backplane. (See Figure 18) When you want to move the system around then one or two additional nuts behind the backplane will ensure your E-blocks stay in place. For best results with this mounting technique you should attach the bolts and self locking nuts and then slacken off the nuts by a quarter turn - this allows the bolts a little movement in the PCB mounting holes and makes them easier to take off the backplane. If you are concerned about preserving the painted finish of your backplane then you can substitute the

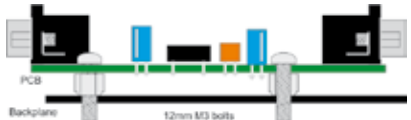

Fig 18 - Board with 12mm bolts

steel bolts with nylon ones. However we have found the powder coating of the backplanes is sufficiently strong not to warrant this.

Using E-blocks on the bench

You do not need a backplane to use E-blocks - you can simply connect them together on the bench. In each E-blocks package you will find a four small rubber feet to facilitate this. These will provide a degree of protection for your E-blocks boards and will help prevent shorts from tinned copper wire and other metal objects on the bench. The disadvantage



Fig 19 - E-blocks on the bench

of this is that your E-blocks system will not be secure and that the connectors will be under more stress as the system is moved about.

Using covers

In some circumstances it is advisable to only allow access to certain parts of the E-blocks boards. This includes situations where settings or chip selections made on E-blocks do not want changing, where there is a chance of vandalism, or where there is a chance of theft of components on the E-blocks themselves. To facilitate this clear acrylic covers are avail-



Fig 20 - Multiprogrammer with clear cover

able for all E-blocks as you can see in Figure 20 with the USB PICmicro microcontroller Multiprogrammer. Covers are mounted onto E-blocks with 25mm M3 bolts and 10mm or 12mm spacers using the same grid of holes that are used for mounting the E-blocks to the backplane. The cross section diagram in Figure 21 shows how this is done. The tight fitting clear acrylic covers add considerable strength to each E-block as well as making

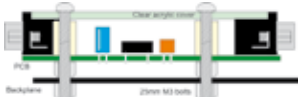

Fig 21 - Cover side profile

them - to some extent - tamper proof. The exception to this is the switch board which, because the switches are relatively short, requires the spacers to be replaced

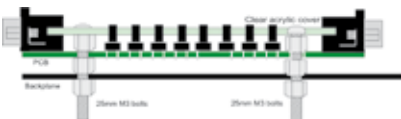

Fig 22 - Switch board with cover

with M3 lock nuts before the cover is put into place. This can be seen in figure 22.

Further security

If you are concerned about the security of your E-blocks systems themselves then it is possible to attach them to a bench using a Kingston style lock as you can see in figure 23.



Fig 23 - Backplane lock

Making your own equipment

In addition to the backplanes it is also possible to buy rugged plastic storage trays for E-blocks. These are slightly larger than a metal backplane which means they are ideal for storage and distribution of E-blocks based systems. In Figure 24 you can see a prototype mobile phone made from E-blocks (with cov-

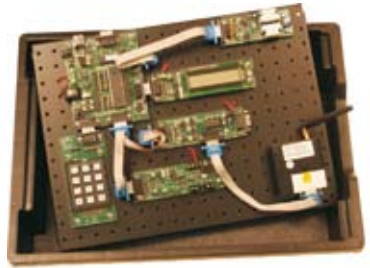

Fig 24 - A completed E-blocks system with tray

ers) and one of the plastic trays. Lids, packing and freight boxes are also available.

Making your own E-blocks

The prototype and patch boards that are part of the E-blocks range, allow you to make E-blocks with your own circuits on.

5 Available E-blocks and accessories

The tables here show some of the products available in the E-blocks range as at March 2007. This range changes on a monthly basis - please see www.matrixmultimedia.com for details.

Upstream boards

EB006	PICmicro MCU Multiprogrammer
EB020	CPLD board
EB030	FPGA board - 3000LE
EB049	FPGA board - 6000LE
EB185	ARM microcontroller programmer
EB194	AVR microcontroller programmer
HP488	PICmicro MCU development board

Downstream boards

EB002	Screw terminal board
EB003	Sensor interface
EB004	LED board
EB005	LCD board
EB007	Switch board
EB008	Quad 7-segment display
EB011*	Power board
EB012	IR/IRDA transmitter receiver
EB013	SPI memory and D/A board
EB014	Keypad board
EB015	RS232 board
EB016	Prototype board
EB017	Patch board
EB018*	CAN bus board
EB021	MIDI board
EB023	Internet board
EB024	Bluetooth board
EB027	LIN bus board
EB028*	X-10 home automation board
EB032	E-blocks Bluetooth CODEC board
EB033*	PS2 and VGA interface board
EB035	Opto-isolator board
EB037	MMC card reader board
EB038	E-blocks relay board
EB039	USB232 interface board
EB043	Graphical LCD display board

Items marked * are not 3.3V compatible

Software / courseware

ELCVRSI	C for AVR microcontrollers CD ROM
EL543SI3	C for 16 series PICmicros V3 CD ROM
ELCRMSI	C for ARM microcontrollers V3 CD ROM
ELFCSSI3	Flowcourse CD ROM
ELPICSI3	Assembly for PICmicros V3 CD ROM
ELPLDSI	Programmable logic techniques CD ROM
EB880	CAN bus comms. manual + CD ROM
EB617	Bluetooth comms. training manual + CD ROM
EB229	Digital comms. and TCP/IP manual + CD ROM
EB230	Mobile phone comms. manual + CD ROM
TELFCLSI3	Flowcode V3

Accessories

EB251	Male to Male E-blocks IDC cable
BP232	Metal backplane - 270 by 350mm
EB634	E-blocks IDC cable
EB635	E-blocks Dual IDC Cable Hardware
EB839	Microchip ICD2
FLLPCK	Prototype board lead pack
HPACT	Actuators training panel
EB182	Mobile phone module



The version 3 PICmicro microcontroller development board is also E-blocks compatible.

Sensors

HPEKG	ECG sensor
HPELEC	ECG electrodes
HS3D	3-Axis Accelerometer
HSACC	Low-g accelerometer
HSBAR	Barometer
HSBPS	Blood pressure sensor
HSCA	Calcium ion-selective sensor
HSCL	Chloride ion-selective sensor
HSCO2	CO2 Gas sensor
HSCOL	Colourimeter
HSCON	Conductivity probe
HSDCP	Current probe
HSDFS	Dual-range force sensor
HSDO	Dissolved oxygen probe
HSDVP	Differential voltage probe
HSEHR	Heart rate monitor
HSFLO	Flow rate sensor
HSFP	Force plate
HSGPS	Gas pressure sensor
HSHD	Hand dynamometer
HSHGH	Heart rate monitor - hand grip version
HSINA	Instrumentation amplifier
HSLGA	Low-g accelerometer
HSLS	Three range light sensor
HSMCA	Microphone
HSMD	Motion detector
HSMG	Magnetic field sensor
HSN03	Nitrate ion-selective sensor
HSNH4	Ammonium ion-selective sensor
HSO2	O2 gas sensor
HSPH	pH sensor and amplifier
HSRH	Relative humidity sensor
HSRM	Radiation monitor
HSRMB	Respiration monitor belt (requires HSGPS)
HSRMS	Rotary motion sensor
HSSAL	Salinity sensor

HSSPA	Smart pulley attachment
HSSPR	Spirometer
HSTAPE	Bar tape
HSTCA	Thermocouple
HSTMP	Wide range stainless steel temperature probe
HSTPL	Extra long temperature probe
HSTRB	Turbidity sensor
HSVDC	Drop counter
HSVPG	Fast response photogate

Note that these are our part numbers - when ordering from your dealer please ensure you use the correct part numbers.

A full list of our international dealers is available on our web site.

Warranty statement

These products should not be used in safety critical, or life support systems. In no circumstances should these products be connected directly to voltage supplies greater than 24V.

Definitions

"The Company" shall refer to Matrix Multimedia Limited.

"The Package" shall refer to the hardware, software and other component parts of this product.

"The Period" shall be one year from the date of delivery.

Warranty

The Company warrants that this Package is free from significant defects in materials and workmanship for the Period. This warranty is not transferable, and does not include software upgrades.

Checking your product

This Package has been tested in the factory in accordance with the Company's quality guidelines. We strongly recommend that you carry out your own tests with this product, in accordance with the User Test guidelines available for the product, which will confirm for you that this Package meets the specification for which it has been designed.

Exclusions

This Package, or parts of it, should not be used in life-critical applications.

This warranty does not apply in the following cases:

- Where a Package that has been damaged as a result of using the Package other than for its intended use
- Where the Package has been modified
- As a result of service by a person not authorized by the Company
- Where damage occurs through improper transportation or packing
- Where this Package is damaged through physical damage
- Where parts of this Package are lost or damaged

To the consumable parts of this Package – e.g. chips or components supplied with this Package including chips on programming systems which can be damaged by erroneous use.

Disclaimer

Except for the limited warranties made in this document the Company disclaims all other warranties – expressed, implied or statutory – including but not limited to implied warranties of merchantability or fitness for a particular purpose. In no event shall the Company be liable for any incidental, special, or consequential damages, including but not limited to loss of business, profits, whether in action, contract or tort or based on a warranty, arising out of or in connection with the use or performance of this Package. The only warranty offered is the repair, or replacement of the Package or parts thereof at the Company's discretion. The Company has the option to offer a refund, at its own discretion, under all circumstances.

Obtaining warranty service

Subject to the provisions above you are entitled to service with respect to the Package with the following terms and conditions: Claims will only be honoured if made within the Period.

- Before making a claim please review the Technical Support section of the documentation – supplied electronically – and contacting our technical support representatives
- If you have problems please contact the Company by phone and your assistance will be required in running any diagnostic tests the Company may feel suitable to ascertain where the problem with the Package lies. This will help in reducing the number of 'no defect found' problems in our service centre.
- Where a diagnostic test by phone identifies one component is at fault the Company may send – by post or courier at the Company's expense – a replacement part.
- Where a diagnostic fault determines that an upgrade of software is required then the Company reserves the right to ship this using email.
- Where it is not possible to determine the fault and repair it remotely then the Package, or parts of it, will need to be returned – at no cost to the Company – to the Company. Please provide proof of purchase and serial numbers for any parts of the Package.
- The company will determine the fault with all returned Packages.
- Where returned Packages are found to be defective in materials or workmanship then the Company will replace or repair the Package at its own expense, and will reimburse for any postal or courier expenditure incurred in sending defective Packages back to the Company.
- Where no fault is found with returned Packages the Company reserves the right to make a reasonable charge to compensate the Company for the time taken to service the Package.